

CARACTERÍSTICAS TÉCNICAS

COLORES

ENCIMERA SUPERIOR, ENCIMERA



26 ALUMINIO
SATINADO



CRISTAL LACOBEL,
PLATA



67 BLANCO
PASTEL



BLANCO, LACOBEL



FRONTAL HPL



31 ROBLE
CANADIENSE



34 CASTAÑO



73 BLANCO BRILLO



74 NARANJA
BRILLO



80 LIMA BRILLO



81 ROJO BURDEOS
BRILLO



102 AMARILLO
BRILLO



108 AZUL BRILLO



127 FUCSIA
BRILLO



148 GRIS



INTERIOR



67 BLANCO
PASTEL



PANELES ESTRUCTURALES DE HPL



73 BLANCO BRILLO



148 GRIS

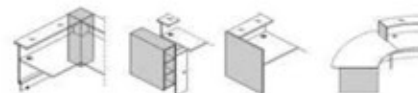

FRONTAL LAD10



26 ALUMINIO
SATINADO



67 BLANCO
PASTEL



PATA DE APOYO EN LA UNIÓN DE ENCIMERAS NL41



M009 ALUMINIO
SEMI-MATE



M015 BLANCO
SEMI-MATE



ARMARIO PARA MOSTRADORES DE RECEPCIÓN



26 ALUMINIO
SATINADO



67 BLANCO
PASTEL



CARACTERÍSTICAS TÉCNICAS

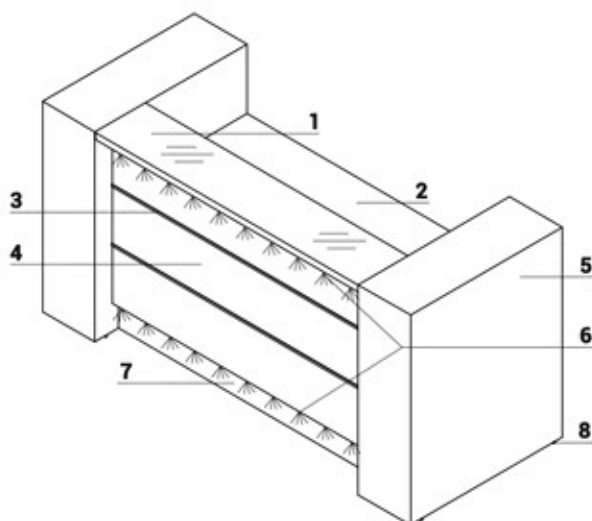

1. Encimera - MFC 36mm con cristal LACOBEL 4mm - se pide por separado
2. Encimera - MFC 28mm, cantos PVC - con o sin rebajes pasacables
3. Franja decorativa - PVC, color M009- aluminio semi-mate
4. Frontal - HPL brillo 3mm
5. Armario como elemento final - MFC 18mm, cantos PVC
6. Iluminación LED – En toda la longitud del mostrador, color blanco frío (tono azulado)
7. Kick plate - HPL - aluminio pulido
8. Nivelación - 0-5mm

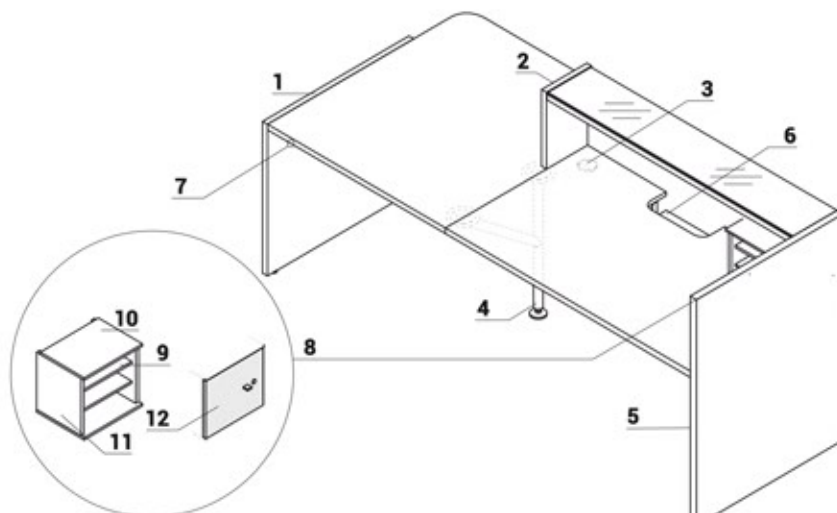

1. Panel lateral bajo - HPL brillo - 38mm
2. Panel lateral de unión entre paneles altos y bajos - HPL brillo - 38mm
3. Tapones pasacables - Ø80mm
4. Pata de apoyo NE41 - metálica, requerida para la unión de encimeras. Colores: M015 – blanco semi-mate, M009 – Aluminio semi-mate, color según color de en
5. Panel lateral alto - HPL brillo - 38mm
6. Opción con recargo - encimera con bandeja inferior para monitor - MFC 28mm, canto PVC
7. Interruptor
8. LMS05 - armario para mostrador de recepción; se pide por separado
9. Estante - MFC 18mm, cantos PVC
10. Encimera - MFC 12mm, cantos PVC
11. Cuerpo - MFC 18mm, cantos PVC
12. Opcional: frontal con cerradura - universal (izda, dcha.) - MFC 18mm, cantos PVC; - se pide por separado

ATENCIÓN - parte interior del frontal en blanco

ARMARIO FINAL

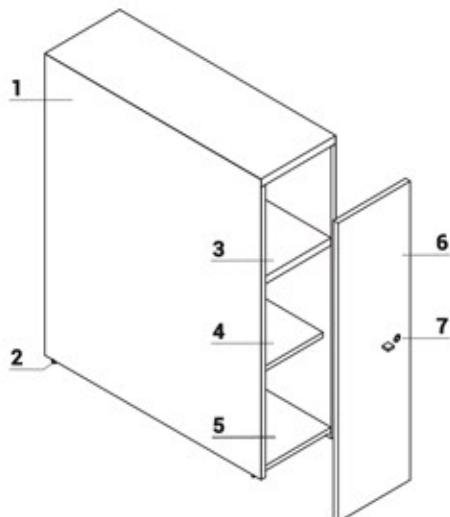

1. Armario como elemento final - MFC 18mm, cantos PVC
2. Nivelación - 0-5mm
3. Estante - MFC 28mm, cantos PVC
4. Estante con posibilidad de regulación de altura - MFC 18mm, cantos PVC
5. Base - MFC 18mm, cantos PVC
6. Frontal opcional LAD10 – MFC 18mm. Universal (izquierda/derecha), se pide por separado
7. Cierre patentado – llave plegable

CARACTERÍSTICAS TÉCNICAS

APLICACIÓN ELEMENTOS FINALES

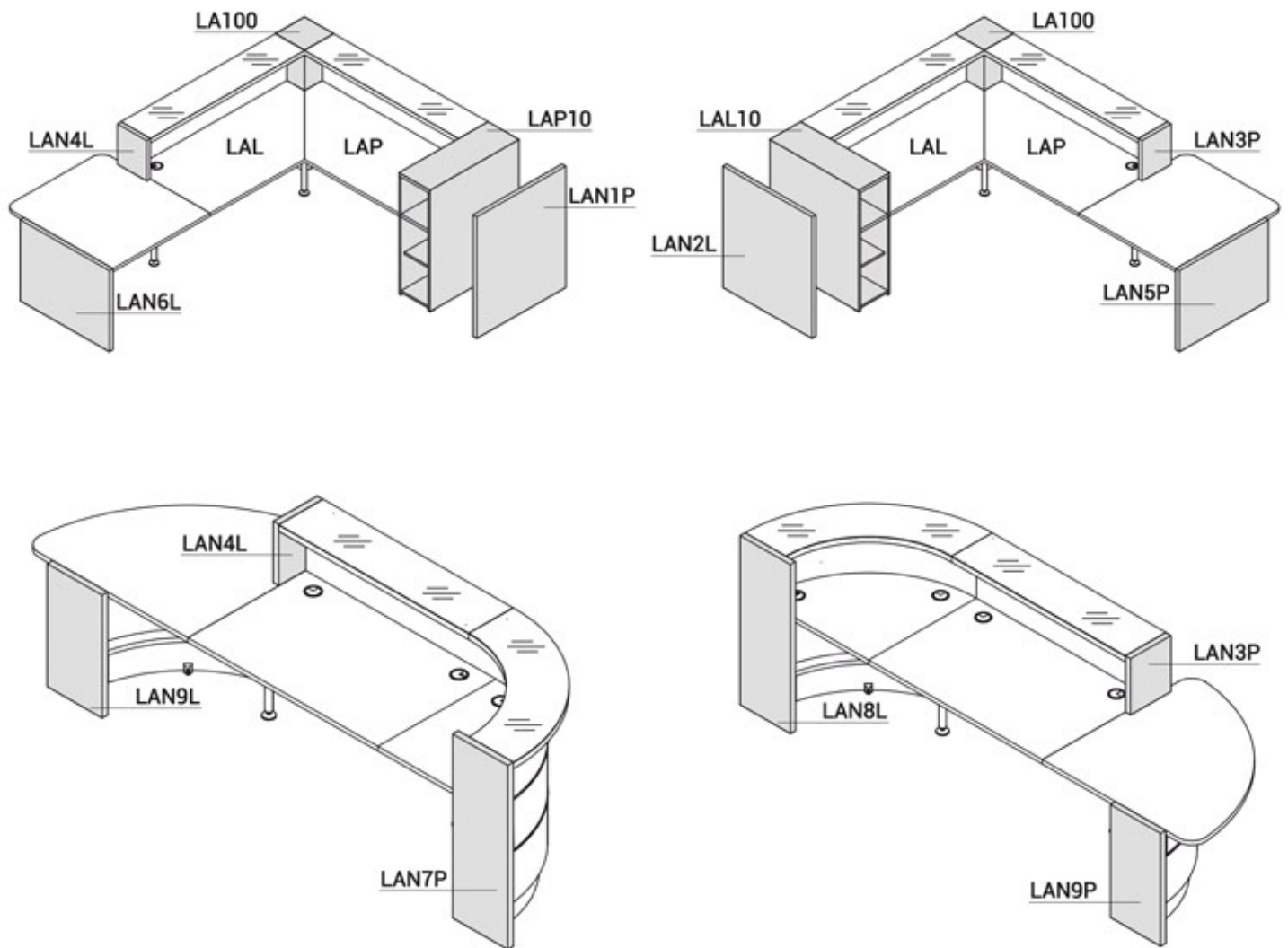

DIMENSIONES

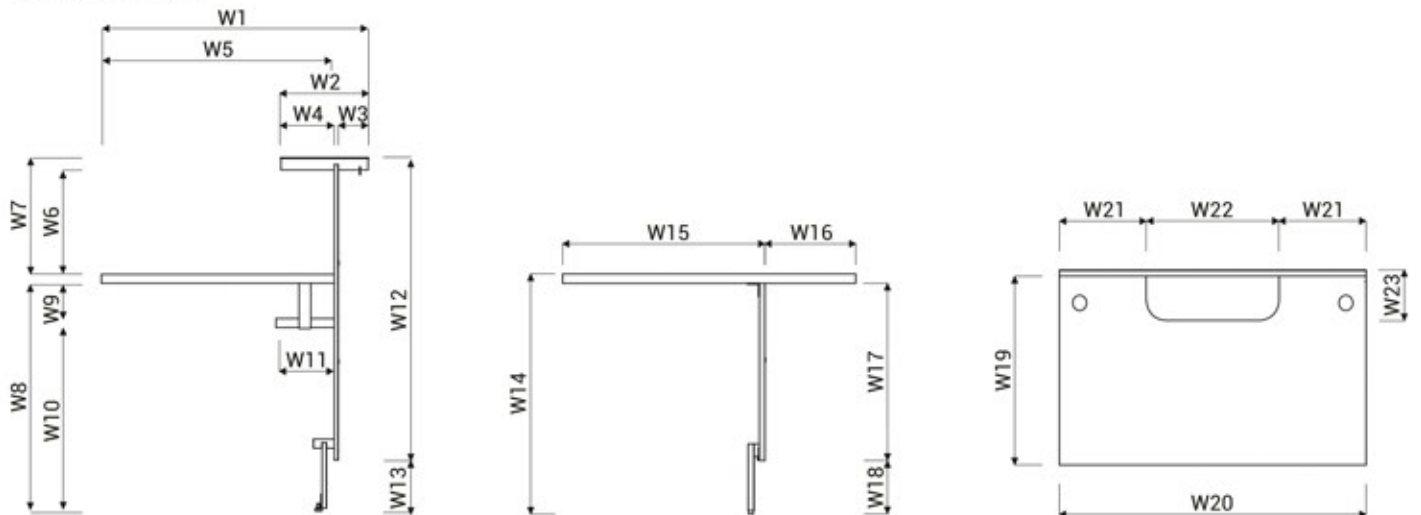

W1 - 916mm | W2 - 300mm | W3 - 103mm | W4 - 183mm | W5 - 800mm | W6 - 324mm | W7 - 364mm | W8 - 712mm | W9 - 110mm | W10 - 574mm | W11 - 200mm | W12 - 944mm | W13 - 150mm | W14 - 740mm | W15 - 814mm | W16 - 300mm | W17 - 580mm | W18 - 160mm | W19 - 800mm | W20 - 1290/1590/2290mm | W21 - 385/535/885mm | W22 - 520mm | W23 - 200mm

SISTEMAS DE MOSTRADORES DE RECEPCIÓN

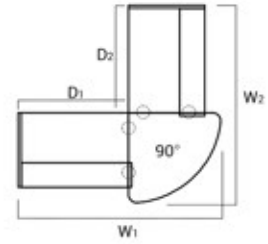
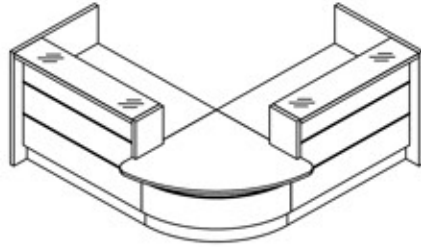

REFERENCIA	DIMENSIONES [mm]						kg	m3	pcs	COMONENTES
	W ₁	W ₂	D ₁	D ₂	H					
LAV101L	2437	2437	1328	1328	1105		204.3	0.950	17	LANZL+LA13L+LANSP+LAV68L+LAN6L+LA13L+LAN1P+2xNL41
LAV102L	2437	2737	1328	1628	1105		217.7	0.997	17	LANZL+LA16L+LANSP+LAV68L+LAN6L+LA13L+LAN1P+2xNL41
LAV103L	2437	3437	1328	2318	1105		244.2	1.121	18	LANZL+LA23L+LANSP+LAV68L+LAN6L+LA13L+LAN1P+2xNL41
LAV104L	2737	2437	1628	1328	1105		217.7	0.997	17	LANZL+LA13L+LANSP+LAV68L+LAN6L+LA16L+LAN1P+2xNL41
LAV105L	2737	2737	1628	1628	1105		231.1	1.044	17	LANZL+LA16L+LANSP+LAV68L+LAN6L+LA16L+LAN1P+2xNL41
LAV106L	2737	3437	1628	2318	1105		257.6	1.168	18	LANZL+LA23L+LANSP+LAV68L+LAN6L+LA16L+LAN1P+2xNL41

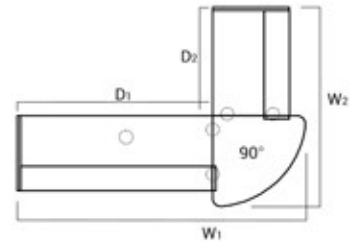
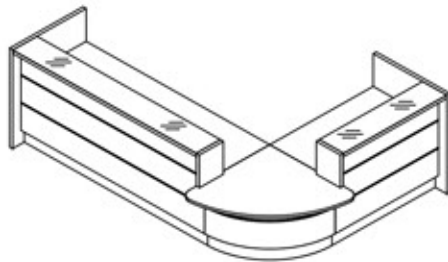

REFERENCIA	DIMENSIONES [mm]						kg	m3	pcs	COMONENTES
	W ₁	W ₂	D ₁	D ₂	H					
LAV107L	3437	2437	2318	1328	1105		244.2	1.121	18	LANZL+LA13L+LANSP+LAV68L+LAN6L+LA23L+LAN1P+2xNL41
LAV108L	3437	2737	2318	1628	1105		257.6	1.168	18	LANZL+LA16L+LANSP+LAV68L+LAN6L+LA23L+LAN1P+2xNL41
LAV109L	3437	3437	2318	2318	1105		284.1	1.293	19	LANZL+LA23L+LANSP+LAV68L+LAN6L+LA23L+LAN1P+2xNL41

RECARGO ADICIONAL

CARACTERÍSTICA	PRODUCTO									kg	m3	pcs	COMENTARIOS
	LAV101L	LAV102L	LAV103L	LAV104L	LAV105L	LAV106L	LAV107L	LAV108L	LAV109L				
BANDEJA PARA MONITOR X 1										0.1	0.0001	1	
BANDEJA PARA MONITOR X 2										0.9	0.0070	1	

DESCRIPCIÓN:

- PESO NETO

- VOLUMEN

- NÚMERO DE PAQUETES

SISTEMAS DE MOSTRADORES DE RECEPCIÓN

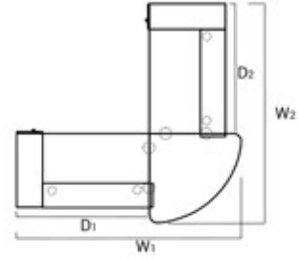
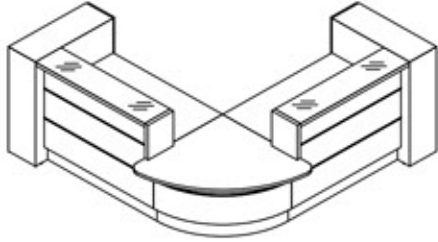

REFERENCIA	DIMENSIONES [mm]						kg	m3	pcs	COMPONENTES
	W ₁	W ₂	D ₁	D ₂	H					
LAV116L	2717	2717	1608	1608	1105		261.3	1.597	19	LAD10+LAL10+LA13L+LAN3P +LAV88L+LAN6L+LA13L+LAP10 +LAD10+2xNL41
LAV117L	2717	3017	1608	1908	1105		274.7	1.644	19	LAD10+LAL10+LA16L+LAN3P +LAV88L+LAN6L+LA13L+LAP10 +LAD10+2xNL41
LAV118L	2717	3717	1608	2608	1105		301.2	1.769	20	LAD10+LAL10+LA23L+LAN3P +LAV88L+LAN6L+LA13L+LAP10 +LAD10+2xNL41
LAV119L	3017	2717	1908	1608	1105		274.7	1.644	19	LAD10+LAL10+LA16L+LAN3P +LAV88L+LAN6L+LA16L+LAP10 +LAD10+2xNL41
LAV120L	3017	3017	1908	1908	1105		288.1	1.691	19	LAD10+LAL10+LA16L+LAN3P +LAV88L+LAN6L+LA16L+LAP10 +LAD10+2xNL41
LAV121L	3017	3717	1908	2608	1105		314.6	1.816	20	LAD10+LAL10+LA23L+LAN3P +LAV88L+LAN6L+LA16L+LAP10 +LAD10+2xNL41

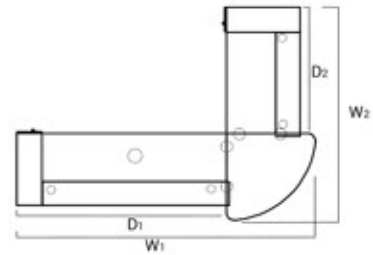
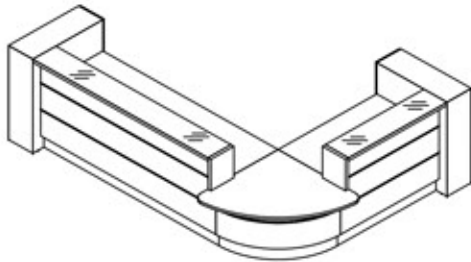

REFERENCIA	DIMENSIONES [mm]						kg	m3	pcs	COMPONENTES
	W ₁	W ₂	D ₁	D ₂	H					
LAV122L	3717	2717	2608	1608	1105		301.2	1.769	20	LAD10+LAL10+LA13L+LAN3P +LAV88L+LAN6L+LA23L+LAP10 +LAD10+2xNL41
LAV123L	3717	3017	2608	1908	1105		314.6	1.816	20	LAD10+LAL10+LA16L+LAN3P +LAV88L+LAN6L+LA23L+LAP10 +LAD10+2xNL41
LAV124L	3717	3717	2608	2608	1105		341.1	1.940	21	LAD10+LAL10+LA23L+LAN3P +LAV88L+LAN6L+LA23L+LAP10 +LAD10+2xNL41

RECARGO ADICIONAL

CARACTERÍSTICA	PRODUCTO									kg	m3	pcs	COMENTARIOS
	LAV116L	LAV117L	LAV118L	LAV119L	LAV120L	LAV121L	LAV122L	LAV123L	LAV124L				
BANDEJA PARA MONITOR X 1										0.1	0.0001	1	
BANDEJA PARA MONITOR X 2										0.9	0.0070	1	

DESCRIPCIÓN:

- PESO NETO

- VOLUMEN

- NÚMERO DE PAQUETES

SISTEMAS DE MOSTRADORES DE RECEPCIÓN

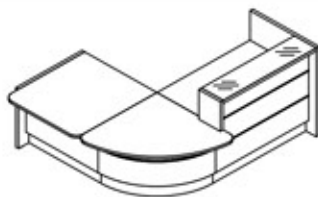

A

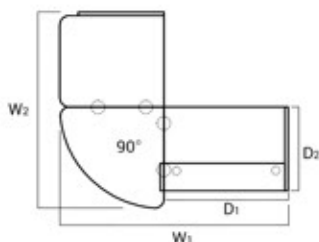

B

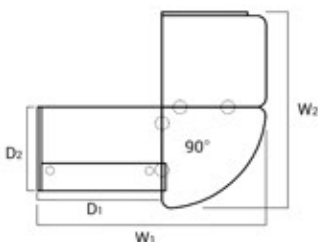

REFERENCIA	DIMENSIONES [mm]					kg	m3	pcs	COMPLEMENTOS
	W ₁	W ₂	D ₁	D ₂	H				
A LAV110L	2442	2147	1328	917	1105	176.4	0.832	16	LANZL+LA13L+LAN3P+LAV68L+LAU11L+LAN5P+2xNL41
B LAV111L	2442	2147	1328	917	1105	176.4	0.832	16	LANSB+LAU11L+LAV68L+LANEL+LA13L+LANIP+2xNL41
A LAV112L	2742	2147	1628	917	1105	189.8	0.879	16	LANZL+LA16L+LAN3P+LAV68L+LAU11L+LAN5P+2xNL41
B LAV113L	2742	2147	1628	917	1105	189.8	0.879	16	LANSB+LAU11L+LAV68L+LANEL+LA16L+LANIP+2xNL41
A LAV114L	3442	2147	2318	917	1105	216.3	1.004	17	LANZL+LA23L+LAN3P+LAV68L+LAU11L+LAN5P+2xNL41
B LAV115L	3442	2147	2318	917	1105	216.3	1.004	17	LANSB+LAU11L+LAV68L+LANEL+LA23L+LANIP+2xNL41
A LAV1101L	2442	1947	1328	917	1105	172.4	0.809	16	LANZL+LA13L+LAN3P+LAV68L+LAU18L+LAN5P+2xNL41
B LAV1111L	2442	1947	1328	917	1105	172.4	0.809	16	LANSB+LAU18L+LAV68L+LANEL+LA13L+LANIP+2xNL41
A LAV1121L	2742	1947	1628	917	1105	185.8	0.856	16	LANZL+LA16L+LAN3P+LAV68L+LAU18L+LAN5P+2xNL41
B LAV1131L	2742	1947	1628	917	1105	185.8	0.856	16	LANSB+LAU18L+LAV68L+LANEL+LA16L+LANIP+2xNL41
A LAV1141L	3442	1947	2318	917	1105	212.3	0.980	17	LANZL+LA23L+LAN3P+LAV68L+LAU18L+LAN5P+2xNL41
B LAV1151L	3442	1947	2318	917	1105	212.3	0.980	17	LANSB+LAU18L+LAV68L+LANEL+LA23L+LANIP+2xNL41

RECARGO ADICIONAL

CARACTERÍSTICA	PRODUCTO											kg	m3	pcs	COMENTARIOS	
	LAV110L	LAV111L	LAV112L	LAV113L	LAV114L	LAV115L	LAV1101L	LAV1111L	LAV1121L	LAV1131L	LAV1141L					LAV1151L
BANDEJA PARA MONITOR X 1													0.1	0.0001	1	

DESCRIPCIÓN:

- PESO NETO

- VOLUMEN

- NÚMERO DE PAQUETES

SISTEMAS DE MOSTRADORES DE RECEPCIÓN

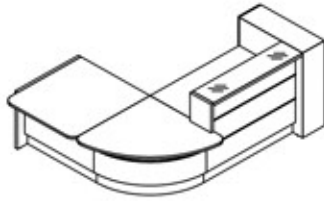

A

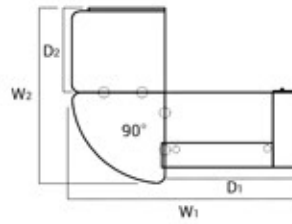

B

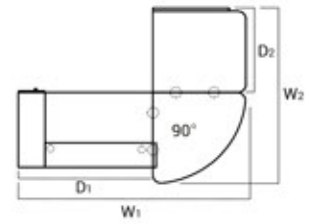

REFERENCIA	DIMENSIONES [mm]					kg	m3	pcs	COMPLEMENTOS
	W1	W2	D1	D2	H				
A LAV125L	2722	2147	1608	1038	1105	206.4	1.162	17	LAD10+LAL10+LA13L+LAN3P +LAV68L+LAU11L+LANSP+2xNL41
B LAV126L	2722	2147	1608	1038	1105	201.9	1.151	16	LAV68L+LAU11L+LAV68L+LAN4L +LA13L+LAP10+LAD10+2xNL41
A LAV127L	3022	2147	1908	1038	1105	215.3	1.198	16	LAD10+LAL10+LA16L+LAN3P +LAV68L+LAU11L+LANSP+2xNL41
B LAV128L	3022	2147	1908	1038	1105	215.3	1.198	16	LAV68L+LAU11L+LAV68L+LAN4L +LA16L+LAP10+LAD10+2xNL41
A LAV129L	3722	2147	2608	1038	1105	241.8	1.322	17	LAD10+LAL10+LA23L+LAN3P +LAV68L+LAU11L+LANSP+2xNL41
B LAV130L	3722	2147	2608	1038	1105	241.8	1.322	17	LAV68L+LAU11L+LAV68L+LAN4L +LA23L+LAP10+LAD10+2xNL41
A LAV1251L	2722	1947	1608	838	1105	202.4	1.138	17	LAD10+LAL10+LA13L+LAN3P +LAV68L+LAU18L+LANSP +2xNL41
B LAV1261L	2722	1947	1608	838	1105	197.9	1.128	16	LAV68L+LAU18L+LAV68L+LAN4L +LA13L+LAP10+LAD10+2xNL41
A LAV1271L	3022	1947	1908	838	1105	211.3	1.175	16	LAD10+LAL10+LA16L+LAN3P +LAV68L+LAU18L+LANSP +2xNL41
B LAV1281L	3022	1947	1908	838	1105	211.3	1.175	16	LAV68L+LAU18L+LAV68L+LAN4L +LA16L+LAP10+LAD10+2xNL41
A LAV1291L	3722	1947	2608	838	1105	237.8	1.299	17	LAD10+LAL10+LA23L+LAN3P +LAV68L+LAU18L+LANSP +2xNL41
B LAV1301L	3722	1947	2608	838	1105	237.8	1.299	17	LAV68L+LAU18L+LAV68L+LAN4L +LA23L+LAP10+LAD10+2xNL41

RECARGO ADICIONAL

CARACTERÍSTICA	PRODUCTO											kg	m3	pcs	COMENTARIOS	
	LAV125L	LAV126L	LAV127L	LAV128L	LAV129L	LAV130L	LAV1251L	LAV1261L	LAV1271L	LAV1281L	LAV1291L					LAV1301L
BANDEJA PARA MONITOR X 1													0.1	0.0001	1	

DESCRIPCIÓN:

- PESO NETO

- VOLUMEN

- NÚMERO DE PAQUETES