

CARACTERÍSTICAS TÉCNICAS

COLORES

ENCIMERA SUPERIOR - CRISTAL



BLANCO, LACOBEL



FRONTAL HPL



73 BLANCO BRILLO



74 NARANJA
BRILLO



80 LIMA BRILLO



81 ROJO BURDEOS
BRILLO



CUERPO



67 BLANCO
PASTEL



PATA DE APOYO EN LA UNIÓN DE ENCIMERAS NL41



M015 BLANCO
SEMI-MATE

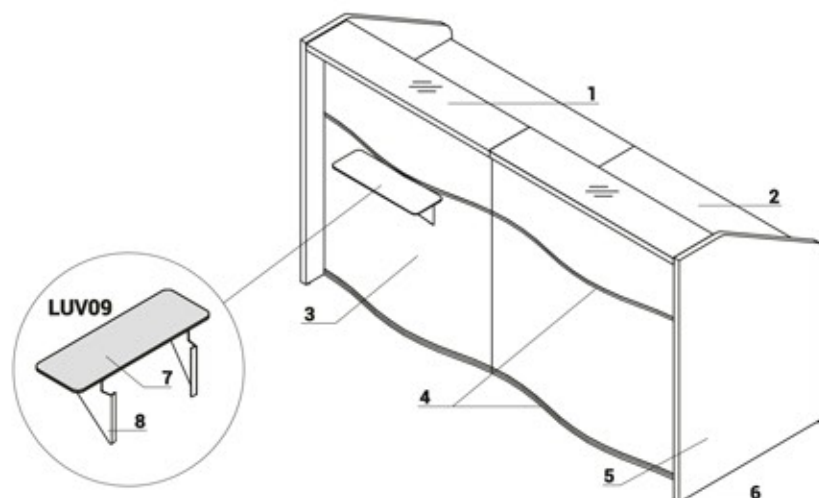

1. Encimera - MFC 36mm con cristal LACOBEL 4mm
2. Encimera - MFC 28mm, cantos PVC - con o sin rebajes pasacables
3. Frontal - HPL brillo
4. Franja decorativa - PVC, color M009- aluminio semi-mate
5. Panel lateral bajo - MFC 28mm, cantos PVC
6. Nivelación - 0-20mm
7. Estante para mostrador de recepción, HPL mate 6mm, se pide por separado
8. Elemento de fijación - metal lacado, color: M015- blanco semi-mate

CARACTERÍSTICAS TÉCNICAS

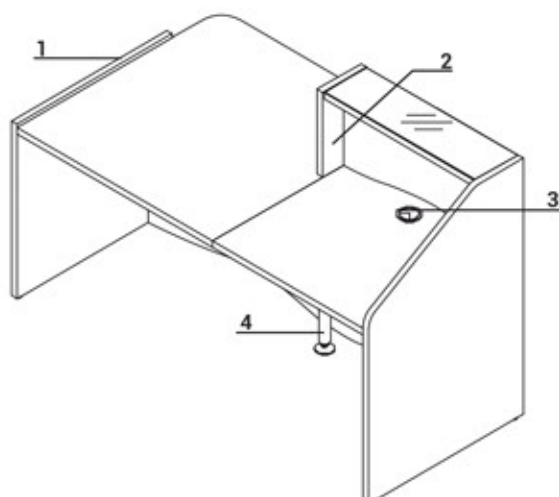

1. Panel lateral bajo - MFC 28mm, cantos PVC
2. Panel lateral de unión entre frentes bajos y altos - MFC 28mm, cantos PVC
3. Tapones pasacables - Ø80mm
4. Pata de apoyo NL41 - necesaria en la unión de encimeras

ATENCIÓN - parte interior del frontal en blanco

APLICACIÓN ELEMENTOS FINALES

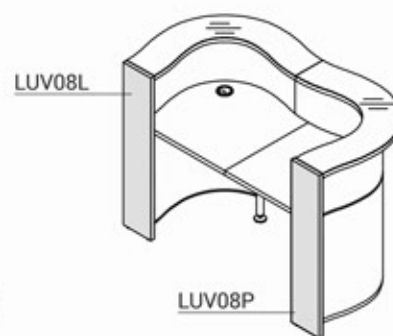
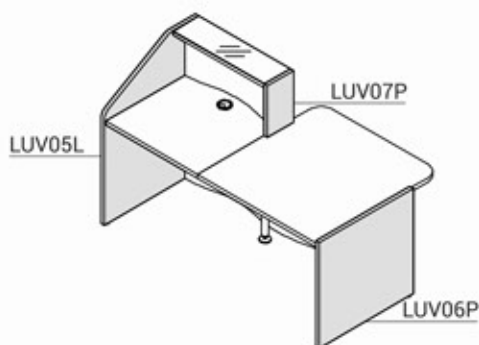
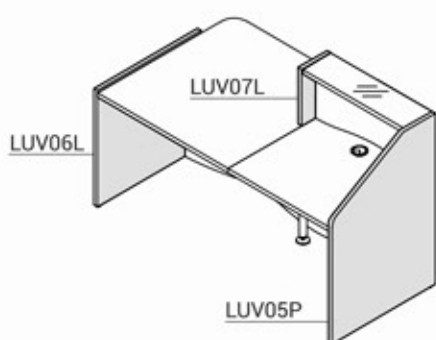

DIMENSIONES

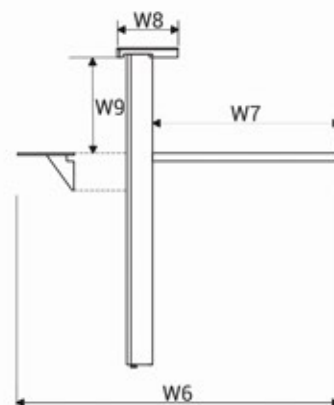
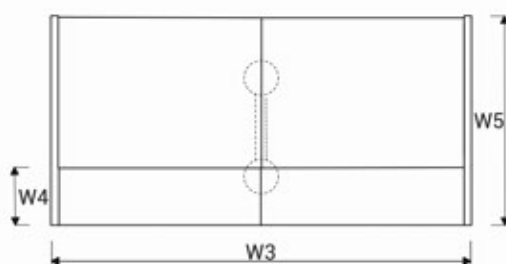
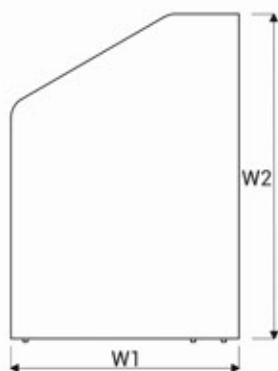

W1 - 770mm | W2 - 1103mm | W3 - 1556mm | W4 - 210mm | W5 - 770mm | W6 - 788mm | W7 - 650mm | W8 - 210mm | W9 - 330mm

SISTEMAS DE MOSTRADORES DE RECEPCIÓN

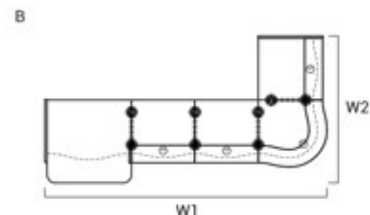
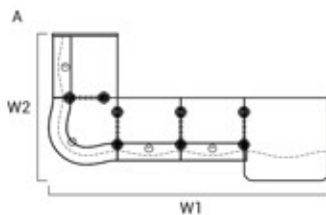
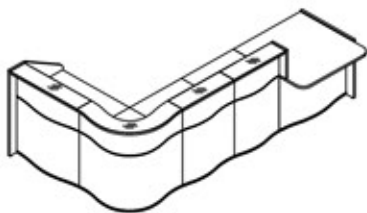

REFERENCIA	DIMENSIONES [mm]						⚖️ kg	📦 m3	📦 pcs		COMPONENTES
	W ₁	W ₂	D ₁	D ₂	H						
A LUV47L	3310	1810	-	-	1103		195.0	1.133	17		LUV08L+LUV01+LUV07L+2xLUV02 +LUV04+LUV03+LUV05P+4xNL41
B LUV47P	3310	1810	-	-	1103		195.0	1.133	17		LUV05L+LUV03+LUV04+2xLUV02 +LUV07P+LUV01+LUV06P+4xNL41
A LUV471L	3110	1810	-	-	1103		189.0	1.107	17		LUV08L+LUV011+LUV07L +2xLUV02+LUV04+LUV03+LUV05P +4xNL41
B LUV471P	3110	1810	-	-	1103		189.0	1.107	17		LUV05L+LUV03+LUV04+2xLUV02 +LUV07P+LUV011+LUV06P +4xNL41
A LUV46L	3750	1810	-	-	1103		199.0	1.169	17		LUV05L+LUV01+LUV07L+2xLUV03 +LUV04+LUV03+LUV05P+4xNL41
B LUV46P	3750	1810	-	-	1103		199.0	1.169	17		LUV05L+LUV03+LUV04+2xLUV03 +LUV07P+LUV01+LUV06P+4xNL41

DESCRIPCIÓN:

⚖️ - PESO NETO

📦 - VOLUMEN

📦 - NÚMERO DE PAQUETES